

Kenmore

INSTRUCTIONS

MODEL 1347 • ZIG • ZAG SEWING



Sears, Roebuck and Co.

Dear Homemaker:

You have just invested in a very fine zigzag sewing machine. Before using your new Kenmore machine, please pause for a moment and carefully read this booklet which contains instructions on how to operate and care for your machine.

Specific instructions are given on threading, tension adjustments, cleaning, oiling, etc. This will help you obtain the best sewing results and avoid unnecessary service expense for conditions beyond our control.

Advice on the operation and care of your machine is always available at your nearest Sears Retail Store. Should you have any further questions on your sewing machine, please write to me at the address given below.

Please remember, any correspondence or reference to your machine must mention the model number and serial number of your machine.

Kenmore Sewing Machine

Record in space provided below the model number and serial number of this appliance. The model number and serial number are located on the nomenclature plate, as identified on Page 2 of this booklet.

Model No. _____ Serial No. _____
Retain these numbers for future reference.

Consumer Services Manager
Department 620
Simpsons-Sears Limited
Toronto, Ontario, Canada

Consumer Services Manager
Department 620
Sears, Roebuck and Co.
Sears Tower
Chicago, Illinois 60684

TABLE OF CONTENTS

Section I	Knowing Your Sewing Machine	
	Identifying Parts	2, 3
	Installing Machine	4
	Winding the Bobbin	5
	Threading the Bobbin Case	6
	Threading of Top Thread	7
	Using the Controls	
	Top Tension Control	8, 9
	Bobbin Tension Adjusting	10
	Checking Tensions	11
	Stitch Width Control	12, 13
	Stitch Length Control	12, 13
	Reverse Stitch Control	14
	Special Stitch Dial	15
	Pressure Regulator	16
	Feed Dog Control	17
	Sewing Light	17
	Seam Guides	18
	Presser Foot Lever	18
	Accessories	
	Needles	19
	Needle, Thread, Fabric Chart	20
	Presser Feet	21
	Buttonhole Attachment	22
Section II	Starting to Sew	1
	Garment Construction Stitches	
	Straight Stitching	2
	Zigzag Stitching	3
	Stretch Stitching	4
	Special Finishing Stitches	
	Satin Stitching	5
	Zipper Application	6
	Buttonhole Making	7
	Appliqueing	8
	Blind Hemming	8, 9
	Mending, Darning	10
	Button Sewing, Bar Tacking	11
Section III	Checking Performance Problems	
Section IV	Caring for the Machine	
	Cleaning Feed Dogs and Shuttle	1
	Oiling Under Arm Cover Plate	2
	Oiling Underside	3
	Oiling in Face Cover Plate	3
	Parts List	5, 6

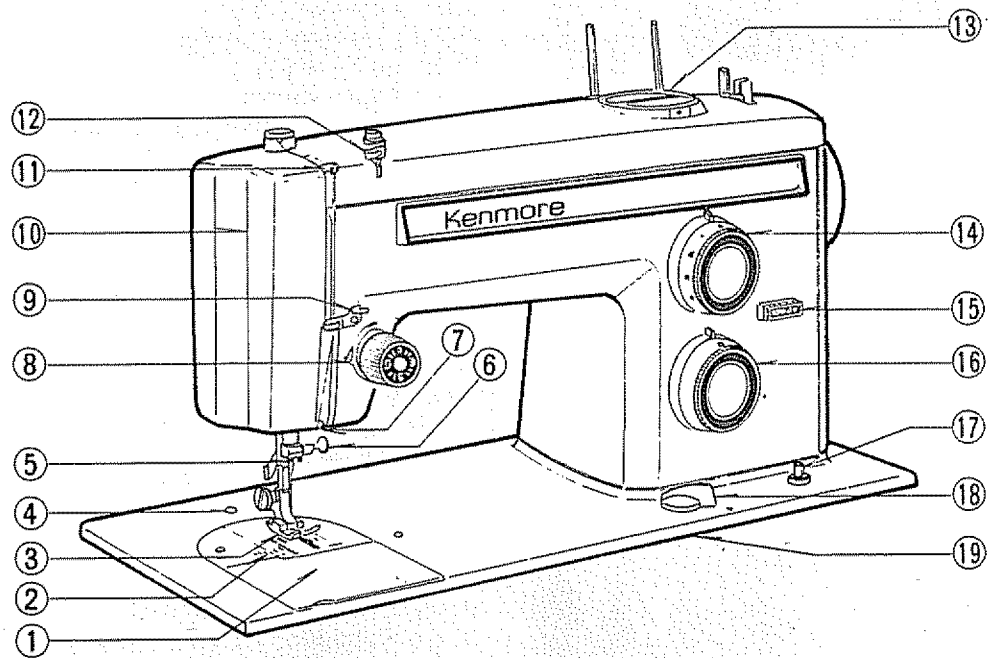

- | | |
|-------------------------------|----------------------------|
| 1. Hand Hole Cover Plate | 11. Take-up Lever |
| 2. Seam Guide Lines | 12. Upper Thread Guide |
| 3. Presser Foot | 13. Special Stitch Dial |
| 4. Guide Pin Hole | 14. Stitch Width Control |
| 5. Thread Guide | 15. Reverse Stitch Control |
| 6. Needle Clamp Screw | 16. Stitch Length Control |
| 7. Face Cover Thread Guide | 17. Light and Power Switch |
| 8. Top Thread Tension Control | 18. Feed Dog Control |
| 9. Thread Guide | 19. Nomenclature Plate |
| 10. Face Cover Plate | |

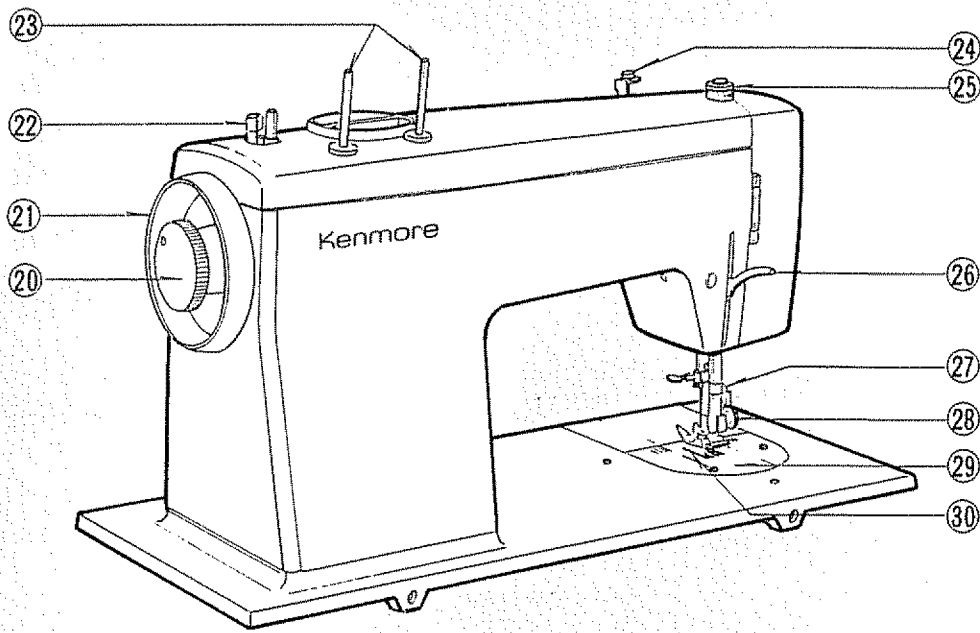

- 20 Clutch Knob
- 21 Hand Wheel
- 22 Bobbin Winder
- 23 Thread Spool Pins
- 24 Bobbin Winder Tension Disc
- 25 Pressure Regulator

- 26 Presser Foot Lever
- 27 Thread Cutter
- 28 Presser Foot Thumb Screw
- 29 Needle Plate
- 30 Feed Dogs

①



②

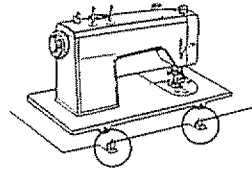

④

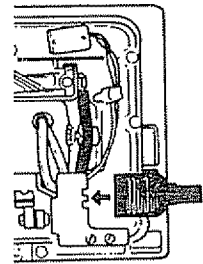

③

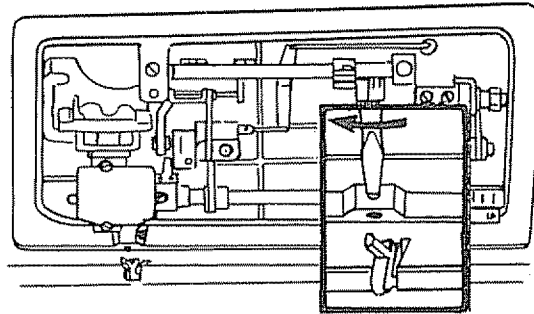

⑤

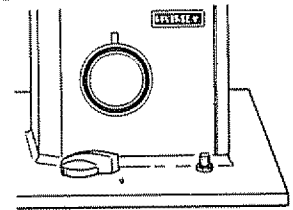

⑥

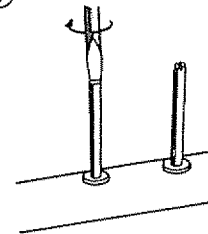

1. Loosen the two hinge screws under holes in the rear edge of the machine bed.
2. Raise hinge pins in the cabinet or case. Slip machine head onto pins.
3. Tighten hinge screws securely.
4. Push the speed control plug onto three-prong connector under the bed plate. Lower machine head to front cabinet flap.
5. Plug machine cord into any 110-120 volt wall outlet. Turn on power by pushing light and power switch.
6. Spool pins are packed in accessory box. Screw thread spool pins in place securely with a screw driver. Position nylon discs as shown in illustration.

①

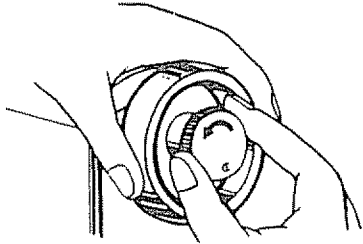

②

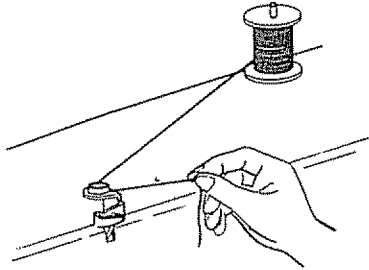

③

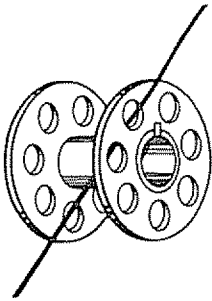

④

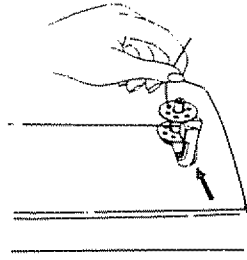

⑤

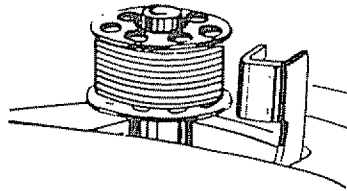

⑥

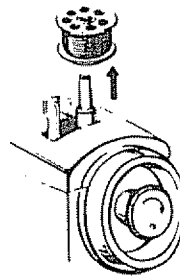

1. Release clutch by turning clutch knob toward you.
2. Draw thread from spool through bobbin winder tension disc as shown.
3. Pull end of thread through hole in bobbin as shown.
4. Place bobbin onto bobbin winder shaft with end of thread coming from the top of the bobbin. Push

- bobbin winder latch against bobbin until it clicks. Holding onto end of thread, start machine. When bobbin is slightly filled, snip off end of thread.
5. Start machine. Wind thread until bobbin winder latch releases.
6. Tighten clutch knob and remove bobbin.

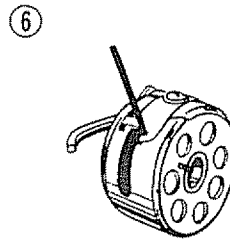
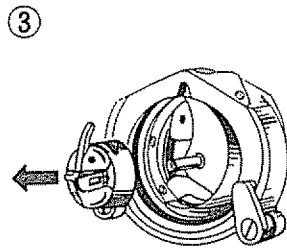
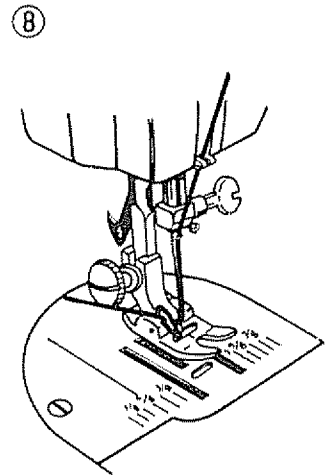
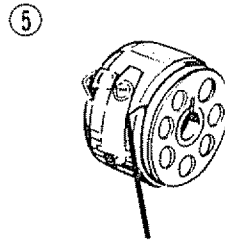
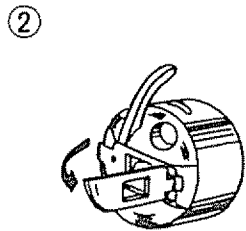
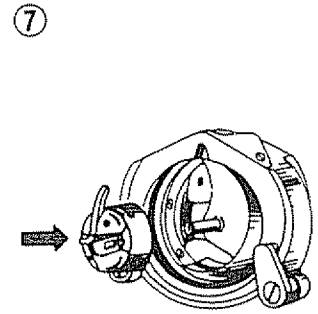
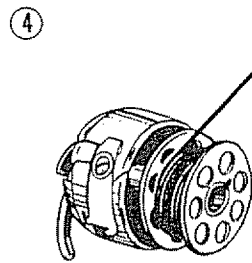
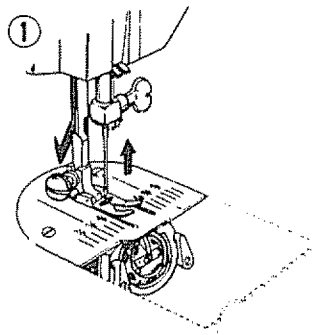

1. To remove bobbin from the shuttle, raise needle to its highest position. Remove hand hole cover plate.
2. Pull open latch of bobbin case.
3. Pull bobbin case straight out of shuttle.
4. Insert bobbin into bobbin case making sure thread is coming from bobbin as shown.
5. Pull thread through slot of case as shown.
6. Pull thread under tension spring.
7. Holding latch open, position case into shuttle, and release latch. Case should lock into place when latch is released.
8. Hold needle thread loosely in left hand and rotate hand wheel toward you one complete turn. Bring bobbin thread up by pulling upper thread.

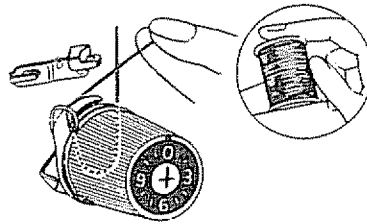
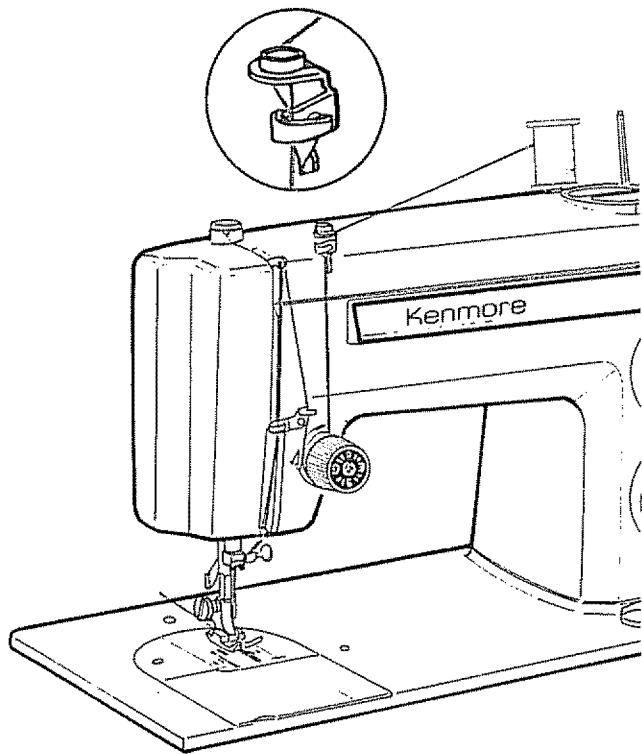

Fig. 1

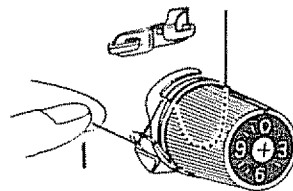

Fig. 2

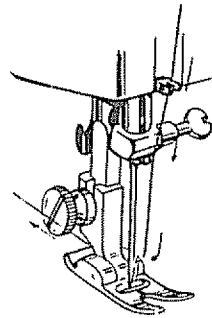
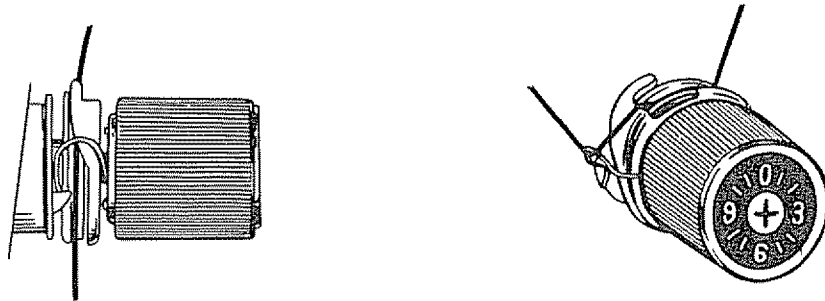

Fig. 3

Place thread on spool pin as shown with thread coming from the back of the spool. Draw thread through the top thread guide. Holding the spool stationary with right hand, pull the end of the thread between the tension discs as shown. Pull the spring wire loop up and past the top hook until the thread

can be slipped into the hook (See Fig. 1). When the thread is released, the spring wire loop will return to position (See Fig. 2) with thread in proper place. Release spool of thread and continue to thread machine exactly as shown. Needle must always be threaded in direction as shown in Fig. 3.



Probably the most important control on your machine is this one that regulates your top thread tension. It consists of discs between which the thread passes. The pressure on these discs is regulated by turning the dial on the front of the control. The higher the number, the tighter the tension.

There are many reasons for having to reset your tension. The best tension for one fabric may not be correct for another. The required tension depends upon the stiffness of the fabric, thickness of the fabric, numbers of layers of fabric being sewn, as well as the type of stitch you are making.

It is best to test the stitching on a scrap of the fabric you are using before starting to make a garment. To adjust for the correct stitch, see next page.

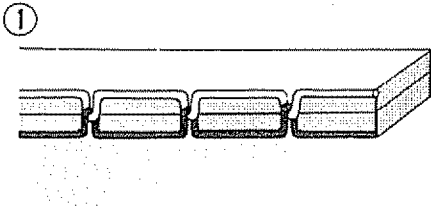

A perfect straight stitch will have threads locked between the two layers of fabric with no loops on top or bottom.

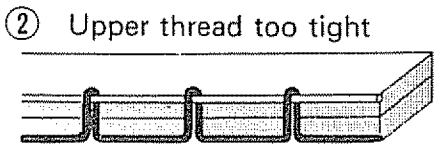

Decrease Tension

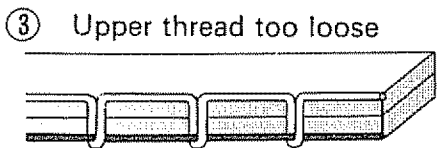
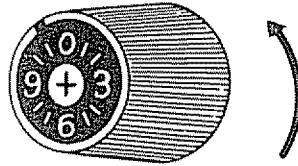

Increase Tension

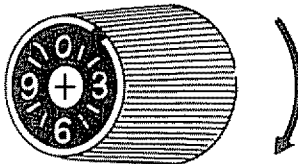

Bobbin tension requires adjusting less frequently than the upper thread tension.

If the stitch is satisfactory but the seam is puckered, it may be necessary to loosen the tension on both the top and bottom threads. Be sure to balance them as indicated on Page 9.

When adjusting the tension on the bobbin case, make slight adjustments with a screwdriver

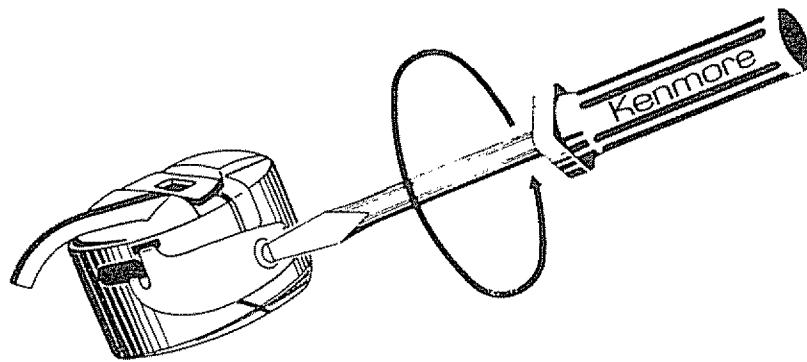

Turn Counter Clockwise.

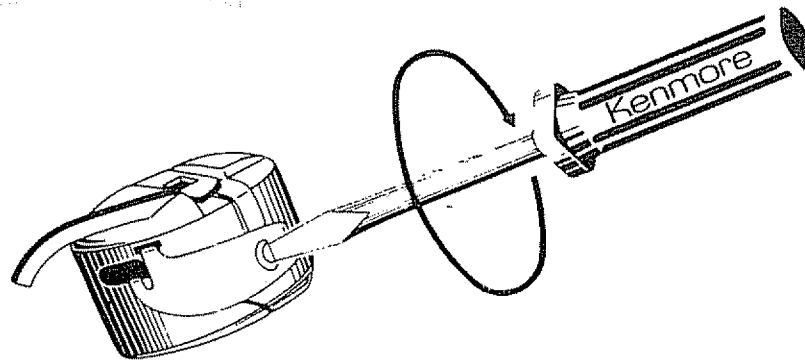

Turn Clockwise.



The easiest way to check tensions is to sew a medium zig zag stitch on the fabric you will be using. Use the appropriate type of thread and needle. Use different colors of thread on the bobbin and upper spool.

Sew a line of zig zag stitches. The bobbin thread should not show on the top of the fabric.

Adjust the top tension if necessary to achieve the stitch balance mentioned above.

UNBALANCED



BALANCED



This control regulates the width of the stitch you select. THE HIGHER THE NUMBER - THE WIDER THE STITCH. You may vary your zigzag stitch width by adjusting this control to the setting you desire.

This control must be on Red Dot in order to do straight stitching

The stitch length control regulates the length of the stitch you select. THE HIGHER THE NUMBER - THE SHORTER THE STITCH.

The number on stitch length control indicates the approximate number of stitches per inch. The stitch setting you use will be determined by the thickness of the fabric you are sewing

A longer stitch setting should be used for thicker fabric or more layers of fabric.

The middle range of the control is the 10-12 stitch per inch range which is the most commonly used.

A basting stitch is made by using the longest possible stitch setting - 6 stitches per inch.

The red marking  on the control is the setting used for the shortest stitches such as in Satin Stitching.

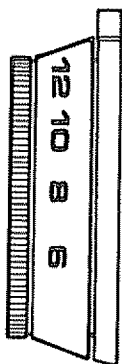
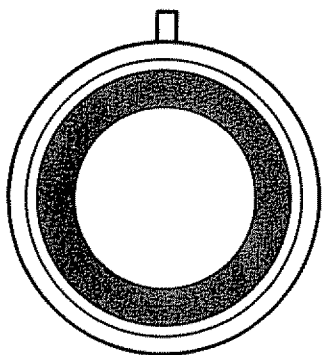
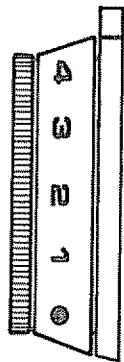
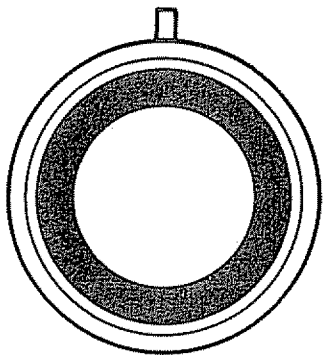



It is best to begin and end seams with a few stitches taken in reverse. This is called back tacking. Back tacking fastens the ends of the seams firmly and prevents raveling.

When reverse stitching is needed, turn the control clockwise and hold there during sewing. The fabric will immediately start feeding backwards and seam will be fastened.

There are certain types of utility stitches you will use often in your home sewing. This control enables you to just dial the stitch you need for the task at hand.

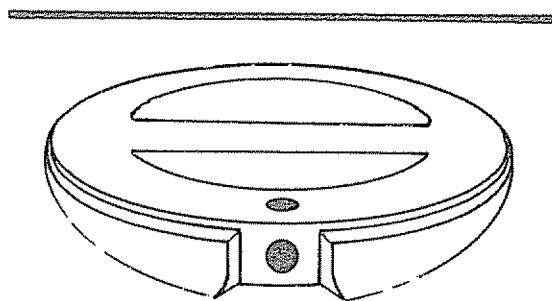

The setting illustrated above is the one used for most of your stitching. At this setting you may straight stitch and make a simple zig zag stitch. As each stitch is dependent upon the settings of your other controls, carefully read the directions in the next section of the book for the various stitches.

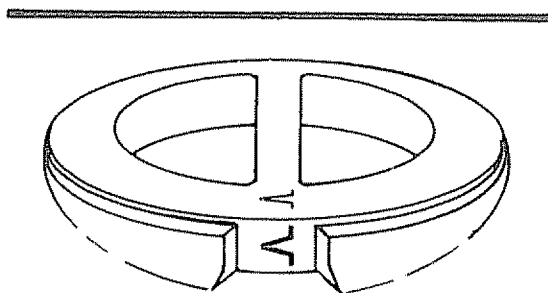

Blind hems are made by using the stitch setting shown in the illustration above. For more detailed instructions in blind hemming, see next section of the book.

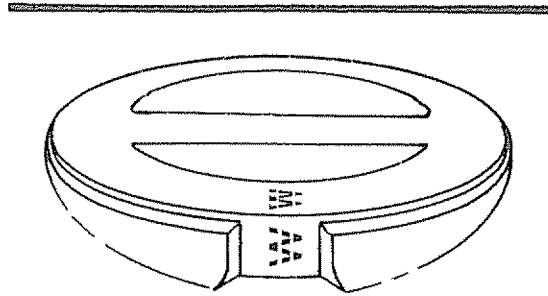

You will find that much of your sewing is in the mending category. For this reason you have been provided with a stitch for the repair of tears. Use of the stitch setting shown is given in more detail in the next section under Mending.

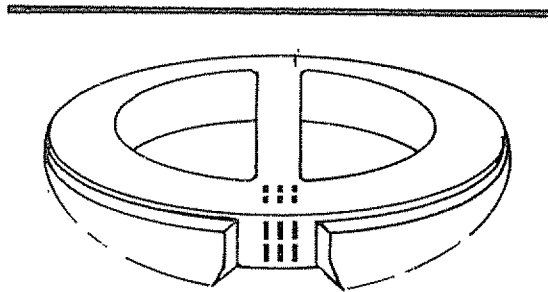

Stretch stitching is easily done by setting the dial to the setting indicated above. Details on the use of this stitch are given in the next section of the book.

In addition to the obvious controls of your machine, there are other small regulators and controls to aid you in using your sewing machine.

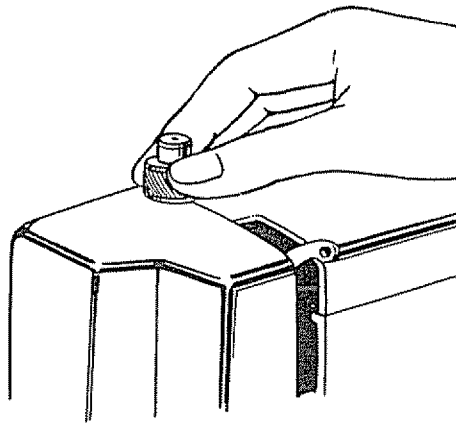

Push down the outer ring of the pressure regulator. This will release the pressure on the presser foot. (See above)
To increase the pressure, push down inner pin until a suitable pressure is obtained.

Insufficient pressure may cause poor feeding of the fabric, skipped stitches, or difficulty in guiding the fabric. If feed dogs or presser foot marks appear on the fabric, reduce the pressure.

When sewing multiple thickness or heavy fabric, reduce the pressure. Increase pressure when sewing lighter weight fabrics.

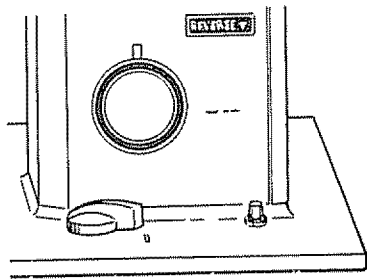

Fig. 1

The feed dog control is located on the right front of the machine bedplate. There are a few times when you want to control the feeding of the fabric yourself. When the control is turned to the left, the feed dogs drop and do not move the fabric.

For most of your sewing, turn knob to the right, "U" (Feed dog up)

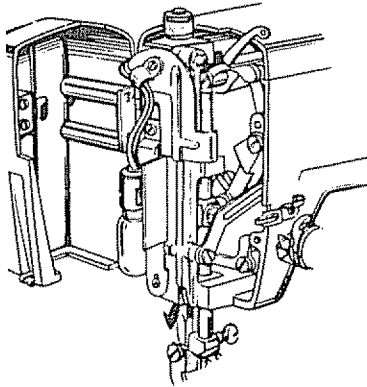

Fig. 2

The light and power switch shown above in Fig. 1 provides the electric current for the motor as well as the light. In order to operate the machine, this switch must be on.

To turn on the light, depress the switch.

If you are interrupted while sewing and must leave the machine unattended, just turn off the switch and the machine cannot be started accidentally.

The sewing light is located inside the face cover plate as shown. To replace the bulb, turn light off, and swing the face cover plate open. Push up on the bulb slightly and turn bulb clockwise. Remove bulb from socket. Push in new bulb and turn counter-clockwise

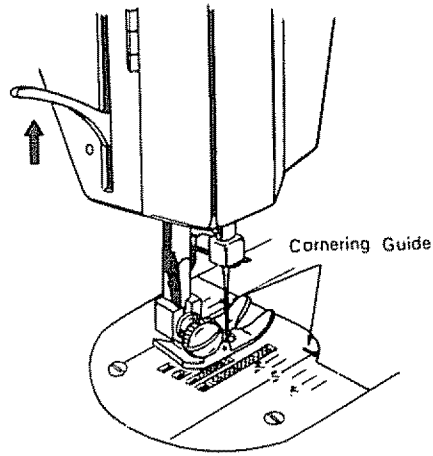

Seam guides are printed on either side of the needle plate to aid you in guiding your fabric. THE GUIDE LINE EXTENDING ABOVE THE RIGHT SIDE OF THE NEEDLE PLATE IS THE "ALL IMPORTANT" 5/8" SEAM LINE.

The cornering guides are convenient when turning a square corner 5/8" from the fabric edge. See next section of this book for directions.

To aid you in the placement of heavy fabrics under the presser foot, the lever can raise the foot beyond the normal "up" position. This is also an aid in changing your presser feet.



Fig 1

Use KENMORE needles. The size of the needle should conform with the size of the thread and both should be suitable to the fabric (See next page).

Never use a bent needle or one with a blunt point.

Fig 1 shows you the exact length of your needle. Be sure you never use one in your machine that is not this exact length.

You will find among your accessories a Q NEEDLE with blue shank. This special needle is to be used when sewing certain knits and certain difficult synthetic fabrics. If you experience skipped stitches in any of your sewing, use Q NEEDLE.

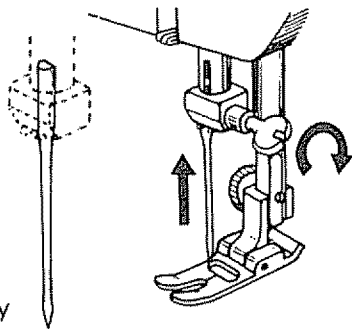

Flat side away from you.

Raise needle bar to its highest position by turning the hand wheel toward you. Loosen the needle clamp screw. Holding the needle with the flat side away from you, slip the needle into the needle bar. When it is in as far as it will go, tighten the needle clamp screw with a screwdriver.

If you have a double needle for decorative stitching, it is inserted in the same manner as the single needle.

THREAD SIZE	NEEDLE SIZE	FABRIC
Polyester Core/Cotton Wrap Fine Mercerized Cotton Polyester Synthetic Silk A	9 or 11	Lightweight: Batiste, Dimity, Chiffon, Silks, Synthetic Jerseys, Fine Lace, Organza, Crepe, Taffetta, Voile, Organdy
50 Mercerized Cotton Polyester Synthetic Silk A	14	Medium Weight: Cotton, Cotton Blends, Percale, Gingham, Shantung, Pique, Seersucker, Satin, Knits, Vinyl, Suitings, Linen, Wool Crepe, Leather
50 Mercerized Cotton Mercerized Heavy Duty Polyester Synthetic Silk A	14 or 16	Medium Heavy Weight: Corduroy, Denim, Wool, Sailcloth, Wool Flannel, Gabardine, Velvets, Leather
Heavy Duty Mercerized Cotton Polyester Synthetic Silk A	18	Heavy Weight: Coatings, Upholstery, Cotton Duck, Heavy Twills, Canvas
Silk Buttonhole Twist	16, 18 or "Q NEEDLE" [™]	Decorative Top-stitching on all
Polyester Synthetic 50 Mercerized Cotton	"Q SET" [™] ("Q NEEDLE" [™] and "Q FOOT" [™])	Synthetic Knits and Stretch Fabrics: Polyester Double Knits, Nylon Tricot, Jersey, Stretch Terry, Spandex, Cire Tricot

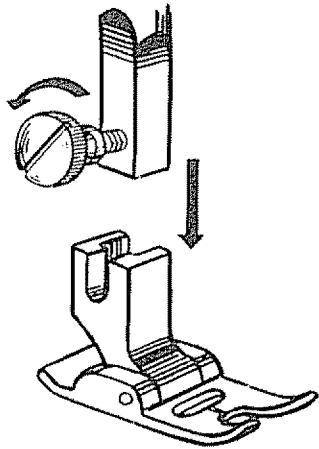

To change the various presser feet, raise the presser bar to its highest position by lifting the presser foot lever. Loosen the presser foot thumb screw, choose the proper foot, insert from the front.

Tighten the screw using the large screw driver to make certain the foot is secure.

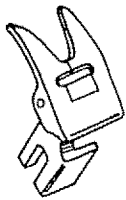

A



B

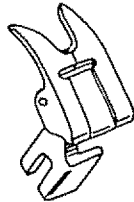

C

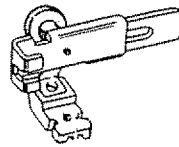

D

You have been given a variety of presser feet:

- A. Zigzag Foot
- B. Straight Stitch Foot
- C. Satin Stitch Foot
- D. Zipper Foot

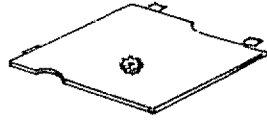

You will find the following parts in your Attachment Box:

1. Cover Plate with pinion gear in the center.

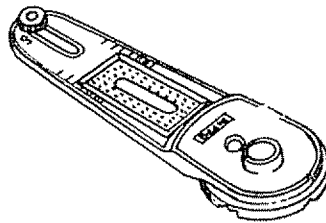

2. Guide Plate with Guide Pin that fits in guide pin hole on machine bed just behind the needle plate.

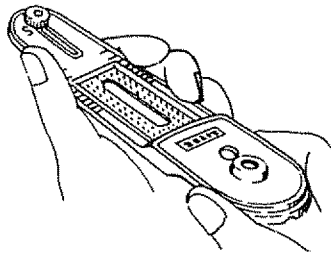

3. Desired size of buttonhole is selected by turning disc. Length of buttonhole appears in window on top side of guide plate.

Details in using this attachment are given in the next section. Follow those directions carefully for perfectly formed buttonholes.

Starting to Sew

Get familiar with the controls on your machine and test its operation. Test your machine on a scrap of material before sewing your machine. Before you make good habits of doing your sewing.

1. Test the needle - it should be straight, properly set and sharp on the point. It should be the correct size for the fabric and thread being used. Do not be afraid to change your needle frequently. Many of the new fabrics made of synthetic blends tend to dull the needles more easily than fabrics made of natural fibers.
2. Before placing the material on the machine, see that the ends of the threads have been drawn about 4 inches to the rear of the machine. Hold on to threads during the sewing of the first 3 or 4 stitches of the seam.
3. Test the machine stitch on a scrap of fabric you plan to use. The fabric should be double thickness. Adjust the machine for the length of stitch and tension suitable to your fabric.
4. Fabric should be placed under the presser foot with the bulk of the material to the left of the needle and the right edge of the material placed on the 5/8" seam marking on the needle plate when making a simple seam.
5. Run the machine at a slow even speed. The more pressure you put on the speed control, the faster the machine will sew.
6. Fasten each seam by back tacking at the beginning and end of the seam.
7. Always finish sewing each seam with the needle at its highest point.
8. Guide the fabric gently with your hand in front of the needle. Never pull or hold the fabric in such a way that the normal feeding is altered.
9. When turning the hand wheel manually, always turn it toward you.

GARMENT CONSTRUCTION STITCHES

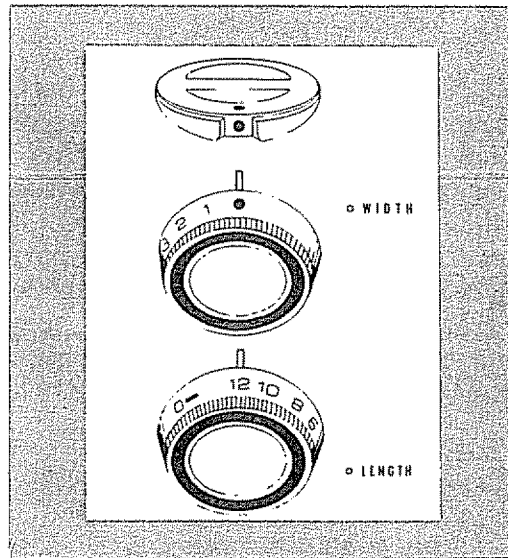

STRAIGHT STITCHING

Set your machine just as shown in the illustration in order to straight stitch. It is important each dial have the following settings.

SETTINGS

Special Stitch Dial - Red Dot
Stitch Width Control - Red Dot
Stitch Length Control - 12 to 6
Straight Stitch Foot

You will find in garment construction that you are doing two types of sewing - temporary and permanent.

1. Temporary stitching - Usually the longest stitch possible and often done on a single layer of fabric. The various types of temporary stitching are:

- Basting
- Stay stitching
- Guide line marking

2. Permanent stitching - This is the actual stitching that holds the garment together. Much of this stitching is visible on the outside of the garment and therefore must be good looking.

The best length stitch to use for medium weight fabrics is 10-12 stitches per inch. This is in the middle range of the Stitch Length Control.

You must remember to lengthen the stitch for heavier fabrics, multiple layers of fabric and thicker seams. Some of these seams are:

- Common two layer seams
- Curved two layer seams
- Top stitched three layer seams
- Top stitched four layer seams

When you have two seams crossing each other with considerable thickness, sew slowly and carefully so seam will be strong as possible in this area.

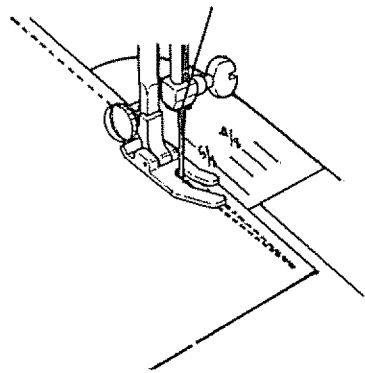

FASTENING A SEAM

Be sure both threads are drawn back under the presser foot. Lower needle into fabric about 1/2 inch from beginning of seam. Turn the reverse stitch control clockwise and stitch in reverse until needle reaches beginning of seam. Release control and complete seam. When you reach the end, turn the control clockwise and sew back over 1/2 inch of completed seam.

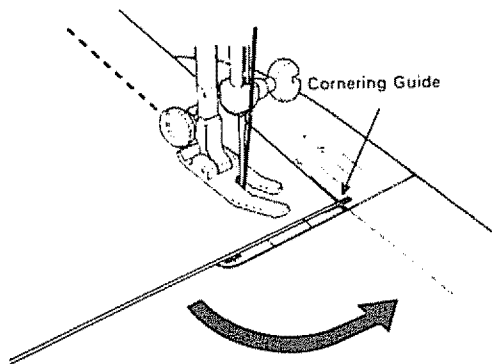

TURNING A SQUARE CORNER

To turn a square corner 5/8" from the fabric edge, stop stitching with the needle tip piercing the fabric, when reaching the cornering guide as shown. Raise the presser foot, turn fabric. New stitching line will align with 5/8" seam guide on side of needle plate. Lower the presser foot and begin stitching in new direction.

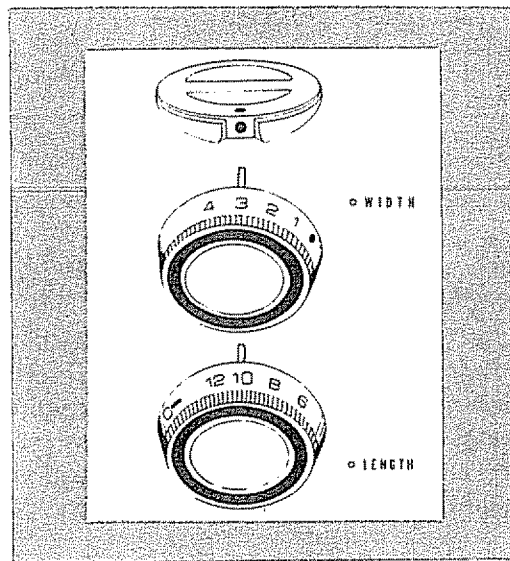

ZIGZAG STITCHING

SETTINGS

Special Stitch Dial - Red Dot
 Stitch Width Control - 1 to 4
 Stitch Length Control - Any Number
 Zigzag Presser Foot

This type of stitching greatly expands the use of your machine. This is the feature that enables you to overcast seams, blind hem, applique, button-hole, monogram, and make all the pretty embroidery designs by machine. Simply use the settings indicated in the illustration for the simple zigzag. Follow directions given in the following pages for more specific uses.

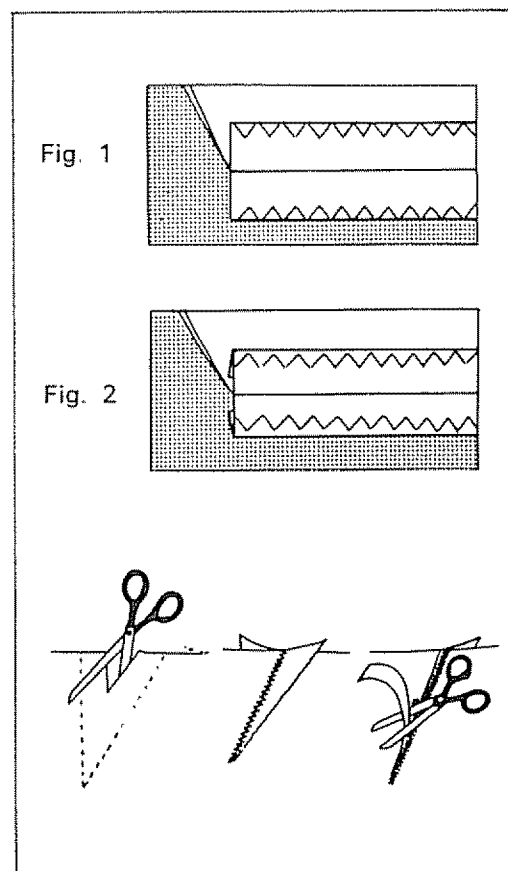

OVERCASTING

This is one of the more frequently used zigzag stitches in garment construction. You may want to overcast along the raw edge of each seam allowance or fold the raw edge toward the garment and stitch.

Fig. 1 shows the raw edge finished. Fig. 2 illustrates the folded edge stitched.

Stitch so the needle pierces the fabric just short of the outside edge. Raw or worn edges of older garments can be overcast to prevent further raveling.

INTERFACING DARTS

To reduce bulk of interfacing darts, cut interfacing down center between dart lines. Overlap cut edges, matching dart lines. Zigzag stitch along marking line from point to wide end of dart. Trim both raw edges close to stitching.

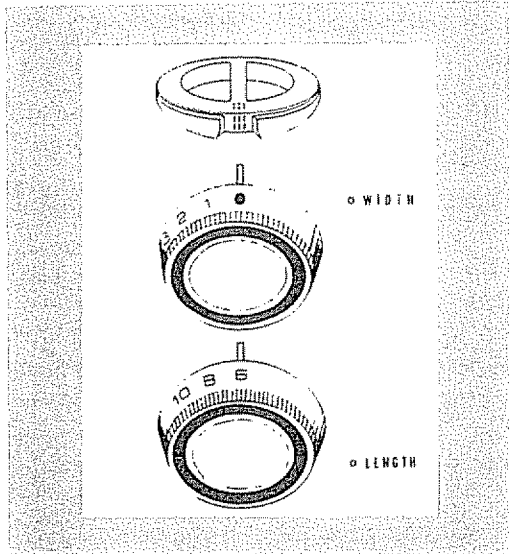

STRAIGHT STRETCH STITCHING

SETTINGS

Special Stitch Dial - III
 Sewing Width Control - 1
 Sewing Length Control - 6
 Zipper Presser Foot

Use this stretch stitch with knitted fabric and other fabrics that stretch. Sew as you do with regular straight stitch seaming. The seam may be pressed open as with any regular seam, but will stretch if necessary.

This is also a good stitch to use on curved seams regardless of the type of fabric. Any seam that will receive a great deal of strain when worn should be sewn with the stretch stitch. Use in children's shorts and slacks as well as adult sports clothes.

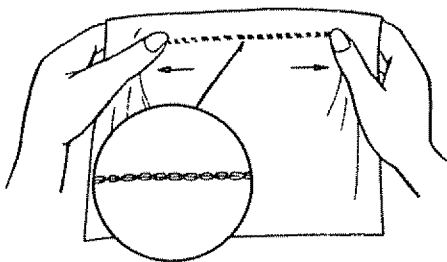

RICK-RACK STRETCH STITCHING

SETTINGS

Special Stitch Dial - III
 Sewing Width Control - 1 to 4
 Sewing Length Control - 6
 Zipper Presser Foot

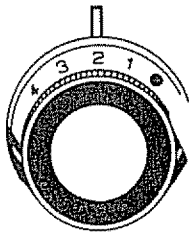

Sew on stretch fabrics in any area that you might use a zig zag stitch. This stitch can be used as a decorative top stitch as well.

SPECIAL FINISHING STITCHES

After the basic construction of your garment is finished, there are still many finishing touches to be done. To aid your completion of your garment, the Kenmore has been designed to do the following tasks that formerly had to be done by hand.

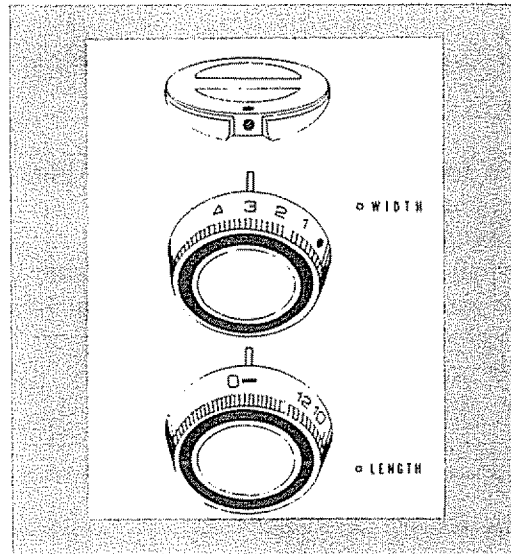

SATIN STITCHING

SETTINGS

Special Stitch Dial - Red Dot
 Stitch Width Control - Any Number 1 to 4
 Stitch Length Control - Red Zone
 Satin Stitch Foot

Closely spaced zigzag stitches are called satin stitches. This is an attractive stitch used for appliqueing, monogramming, buttonhole making.

Whenever you are using this stitch, it is well to remember to loosen the tension of the top thread slightly. The wider the stitch you make, the looser the tension should be.

If you are stitching on a very soft fabric, it is well to use a backing of tissue paper or interfacing for a well formed stitch. Puckering of the material will be eliminated and the bobbin thread will not be visible on the right side of the fabric.

As with all special stitches, it is best to make a sample design on your fabric before starting the design on the garment.

ZIPPER APPLICATION

DETAILS

General Duty Zipper Foot
Blind Stitch Zipper Foot
Blind Stitch Zipper Foot
Decorative

REGULAR ZIPPER

The foot is adjustable for use on the right or left side of the needle when sewing the regular type of zipper. Adjust the foot so the needle clears the side notch on the foot. See Fig. 1. Carefully follow directions given on the zipper package.

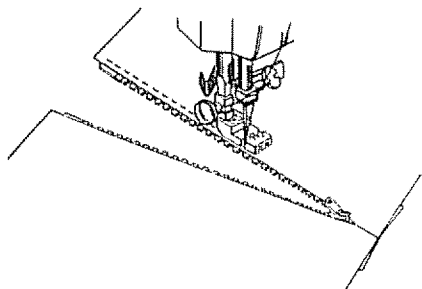

Fig. 1

INVISIBLE ZIPPER

Adjust the foot so the needle is sewing through the center hole of the foot and one groove of the foot is riding on the teeth of the zipper. See Fig. 2. Follow the zipper manufacturer's instructions.

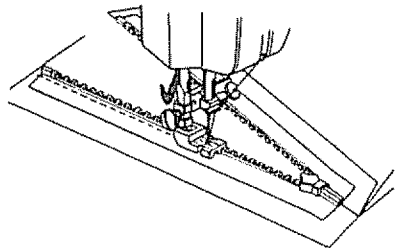

Fig. 2

After zipper has been inserted, finish sewing seam by shifting foot to side position sewing through side notch.

CORDING

Foot can also be used to make cording for slipcovers etc. Cover a cord with a strip of bias fabric and sew as shown in Fig. 3.

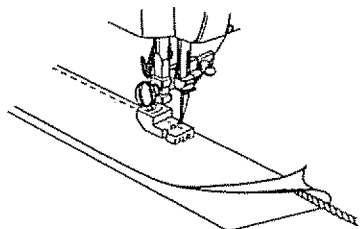

Fig. 3

BUTTONHOLE MAKING

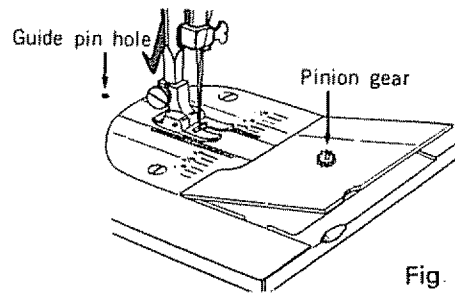

Fig. 1

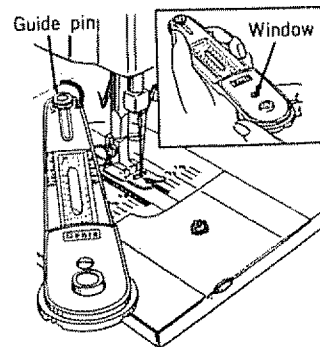

Fig. 2

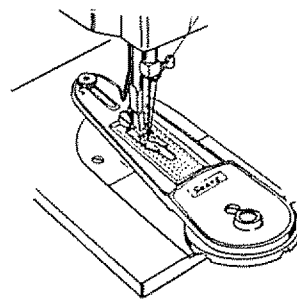

Fig. 3

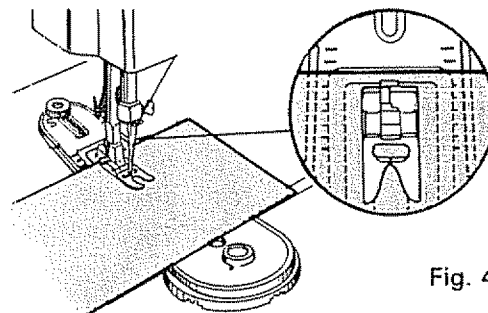

Fig. 4

SETTINGS

Special Stitch Dial - Red Dot
Stitch Width Control - 1 to 1½
Feed Dogs - Down
Satin Stitch Foot

- 1 Remove regular cover plate and insert buttonhole cover plate.
- 2 Select desired size of buttonhole by turning disc as shown. Length of buttonhole appears in window on top side of guide plate. Screw guide pin on guide plate into guide pin hole on machine bed.
- 3 Pull guide plate all the way forward so that guide pin is at S. This will enable you to start at one end of the buttonhole. Drop guide plate into place over the pinion gear.
- 4 Pick up bobbin thread through guide plate by turning hand wheel and drawing thread to back of machine. Place fabric between presser foot and guide plate. Line up edge of fabric with marked indentation on guide. See Fig 4. If you wish all buttonholes to be 3/4 inch from edge of garment, line up fabric with 3/4 inch marking each time you start sewing a buttonhole.

Always make a practice buttonhole on a scrap of fabric you plan to use. Try the buttonhole with the button you will use.

Always use an interfacing in area of garment where buttonholes are placed. Tissue paper or regular interfacing can be used. Tear paper away after stitching, if it is used.

For heavier weight fabrics, loosen your top tension slightly and use a wider stitch width setting.

APPLIQUEING

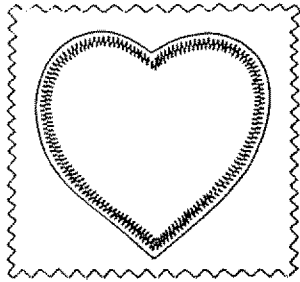

SETTINGS

Special Stitch Dial - Red Dot
Stitch Width Control - 1
Stitch Length Control - Red Dot
Satin Stitch Foot

Select an applique design to be applied to your garment and baste it in place. Satin stitch around the raw edge of the applique completely covering the edge. You may want to do this with a contrasting color of thread or self color.

BLIND HEMMING

SETTINGS

Special Stitch Dial - #
Stitch Width Control - 2 to 3
Stitch Length Control - 12 to 10
Zigzag Presser Foot

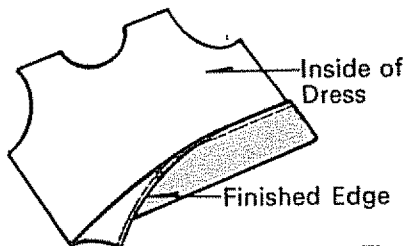
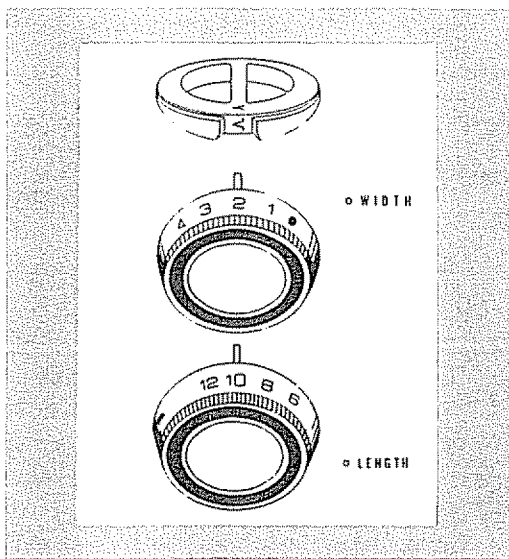

Fig. 1

1. Finish edge of hem anyway you desire. Turn up hem appropriate width. (Fig. 1)

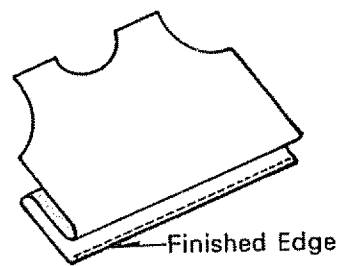

Fig. 2

2. Fold garment away from hem leaving 1/8" of hem edge extending. (Fig. 2)

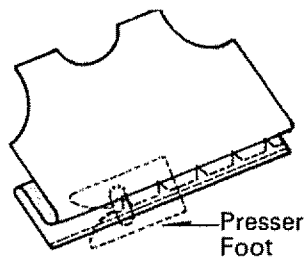

Fig. 3

3. Place garment under presser foot in such a manner that straight stitches will be sewn on extended edge. The zigzag stitch should just catch the fold of the garment. (Fig. 3)

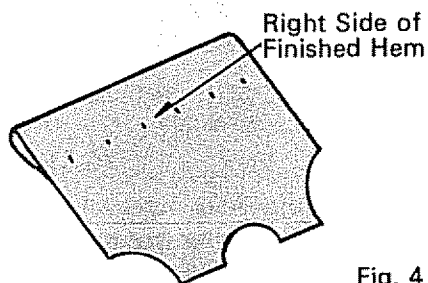
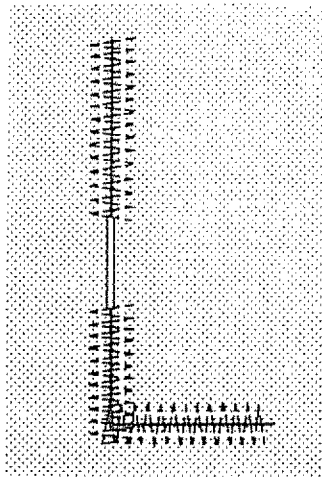

Fig. 4

4. Press both sides of the finished hem. The right side of the garment will show only the blind stitches. (Fig. 4)



MENDING

SETTINGS

Quadrant Stitch Dial - 3
Stitch Width Control - 0
Stitch Length Control - Red Zone
Upper Presser Foot

To repair a straight or three-cornered tear, position the tear under the needle in such a way that the stitching catches both sides of the tear. When mending a three-cornered tear, stitch from each end to the center. It is well to use a piece of fabric under the tear for reinforcement.

DARNING

SETTINGS

Stitch Width Control - Red Zone
Foot Dogs - Up
No Presser Foot

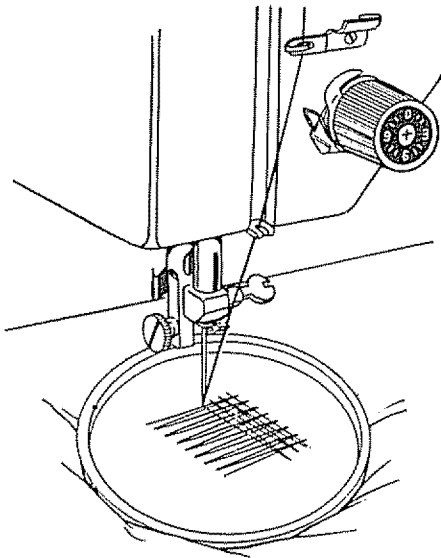

Remove presser foot, stretch fabric between embroidery hoops with hole centered. Draw the bobbin thread up through the fabric by holding the top thread and taking one stitch at the spot where you wish to start darning. Lowering the presser bar, start sewing at a slow to medium speed. Move the fabric back and forth with a steady rhythm to cover the darning area. When it is covered, turn the fabric and sew another layer of stitching across the first layer of stitching.

BUTTON SEWING

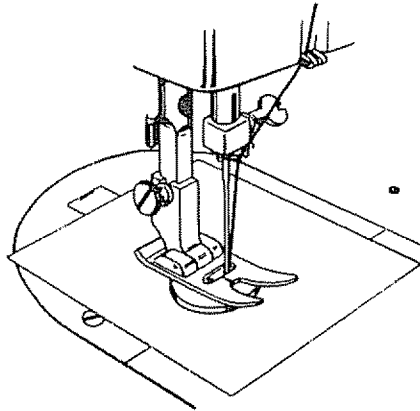

SETTINGS

Special Stitch Dial - Red Dot
Feed Dogs - Down
Zigzag Presser Foot

1. Align two holes of button with slot of presser foot and lower foot to hold the button securely.
2. Turn hand wheel manually until needle point is just above button.
3. Adjust stitch width control so needle will enter left hole of the button.
4. Turn hand wheel again by hand so needle enters second hole. Re-adjust stitch width if necessary. Stitch a number of times.
5. Finish sewing with an extra two inches of thread remaining. Draw these threads to reverse side of garment and tie.

BAR TACKING

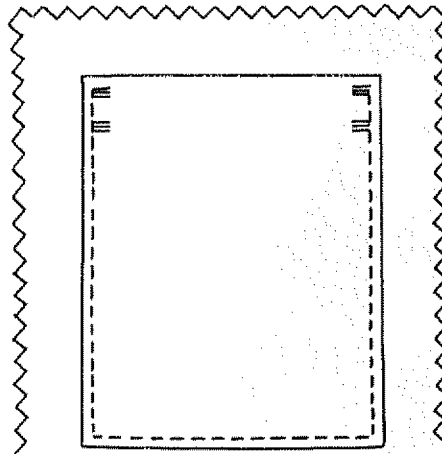

SETTINGS

Special Stitch Dial - Red Dot
Stitch Width Control - 2 to 4
Stitch Length Control - Red Zone
Zigzag Presser Foot

This stitch is similar to a very short satin stitch and is used to reinforce points of strain such as corners of pockets and straps on lingerie.

Sew 4 to 6 zigzag stitches.

Checking Performance Problems WHAT TO DO

PROBLEM	PROBABLE CAUSE	CORRECTION
Irregular Stitches	<p>Incorrect size needle. Improper threading. Loose upper thread tension. Pulling fabric. Light pressure on presser foot. Loose presser foot. Unevenly wound bobbin. Nicks or burrs on shuttle. Nicks or burrs at hole of needle plate.</p>	<p>Choose correct size needle for thread and fabric. Rethread machine. Tighten upper thread tension. Do not pull fabric; guide it gently. Increase pressure on presser foot. Reset presser foot. Rewind bobbin. Replace shuttle, or polish off burrs completely. Replace needle plate, or polish off burrs completely.</p>
Breaking Needle	<p>Pulling fabric. Incorrect size needle. Incorrect setting of needle. Loose presser foot.</p>	<p>Do not pull fabric; guide it gently. Choose correct size needle for thread and fabric. Reset needle. Reset presser foot.</p>
Bunching of Thread	<p>Upper and lower threads not drawn back under presser foot before starting seam.</p>	<p>When starting a seam be sure to draw both threads under and back of presser foot about 4" and hold until a few stitches are formed.</p>
Puckering	<p>Incorrect thread tension(s). Light pressure on presser foot. Using two different sizes or kinds of thread. Bent or blunt needle. Loose presser foot. Fabric too shear or too soft.</p>	<p>Reset thread tension(s). Increase pressure on presser foot. Upper thread and bobbin thread should be same size and kind. Insert new needle. Reset presser foot. Use underlay of tissue paper.</p>

PROBLEM	PROBABLE CAUSE	CORRECTION
<p>Skipping Stitches</p>	<p>Incorrect size needle. Certain knits and synthetics. Bent or blunt needle. Incorrect setting of needle. Tight upper thread tension. Light pressure on presser foot.</p>	<p>Choose correct size needle for thread and fabric. Use "Q.N.F.I.F."™. Insert new needle. Reset needle. Loosen upper thread tension. Increase pressure on presser foot.</p>
<p>Breaking Upper Thread</p>	<p>Starting to stitch too fast. Improper threading. Tight upper thread tension. Incorrect size needle. Sharp eye in needle. Nicks or burrs on shuttle. Nicks or burrs at hole of needle plate.</p>	<p>Start to stitch at a medium speed. Rethread machine. Loosen upper thread tension. Choose correct size needle for thread and fabric. Insert new needle. -Replace shuttle, or polish off burrs completely. Replace needle plate, or polish off burrs completely.</p>
<p>Breaking Bobbin Thread</p>	<p>Improper bobbin case threading. Tight bobbin thread tension. Lint in bobbin case or shuttle.</p>	<p>Check bobbin case threading. Loosen bobbin thread tension. Clean bobbin case and shuttle.</p>
<p>Fabric not Moving</p>	<p>Feed dog down. Light pressure on presser foot. Thread knotted under fabric.</p>	<p>Raise feed dog. Increase pressure on presser foot. Place both threads back under presser foot before beginning to stitch.</p>
<p>Machine Jamming Knocking Noise</p>	<p>Thread caught in shuttle.</p>	<p>Disassemble and clean shuttle.</p>

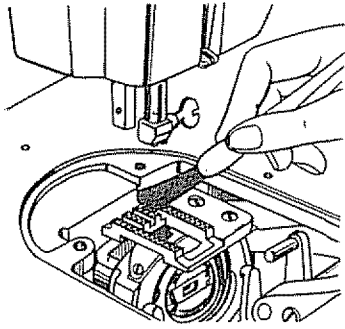
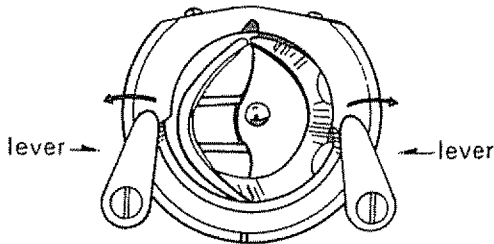

Fig 1

Fig. 1 Cleaning the feed dogs with a brush.

To insure the best possible operation of your machine, it is necessary to keep the essential parts clean at all times. Using a small brush, remove the lint that accumulates in the shuttle area and around the feed dogs.



Shuttle Assembly

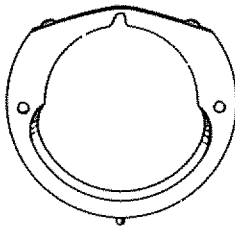

Shuttle Race Cover

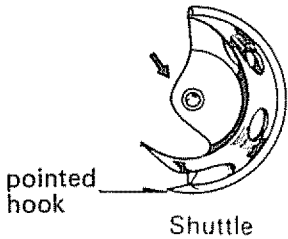

Shuttle

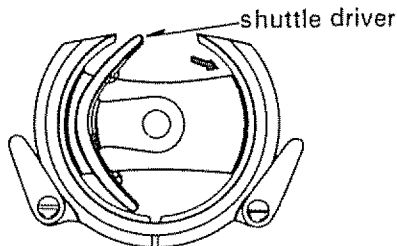

Shuttle Race

Fig. 2 Parts of the Shuttle Assembly

To Clean the Shuttle Area:

1. This area must be kept free of dust, lint and occasional tangled thread. Raise the needle bar to its highest point and remove the bobbin case.
2. Push levers of shuttle race aside and lift shuttle race cover and shuttle out.
3. Clean the shuttle race with small brush.
4. Put a drop of oil on the center pin of the shuttle and shuttle race. (see arrows)

To Replace Shuttle Assembly:

1. Position shuttle race as illustrated so that shuttle driver is forming half moon on the left side of the machine.
2. Hold shuttle by center pin and position shuttle so as to form a half moon on the right side. Pointed hook will be on the bottom.
3. Place shuttle race cover into place over shuttle assembly.

Fig 2

REMOVE COVER PLATE TO OIL POINTS

Remove arm cover plate to oil points indicated in top of machine head. To remove cover plate, insert a screw driver into the spacing between arm casting and top cover plate and lift the cover plate as illustrated below.

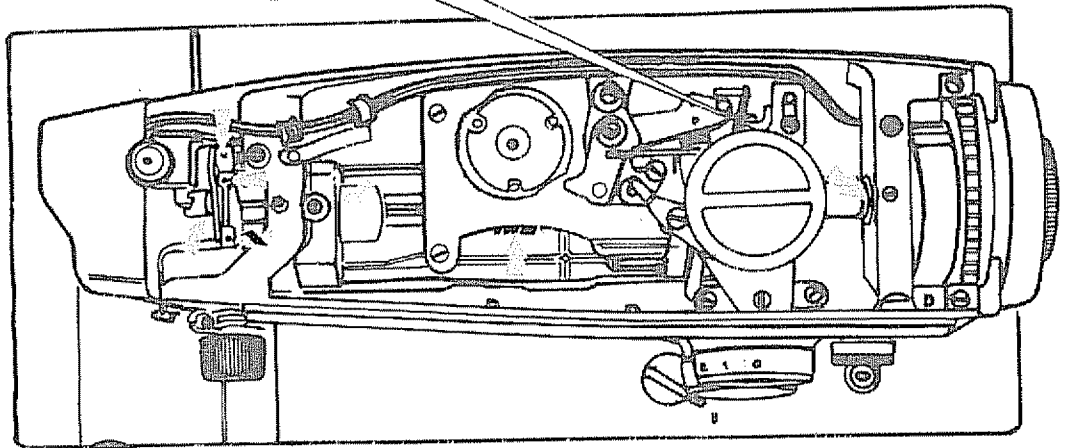
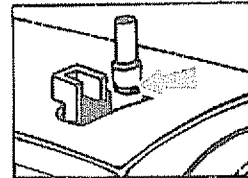
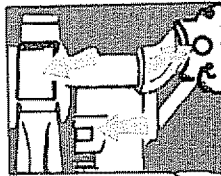
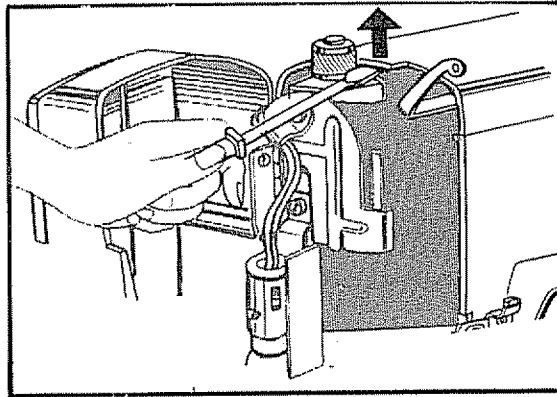

Tilt machine head back to oil points indicated on underside of machine

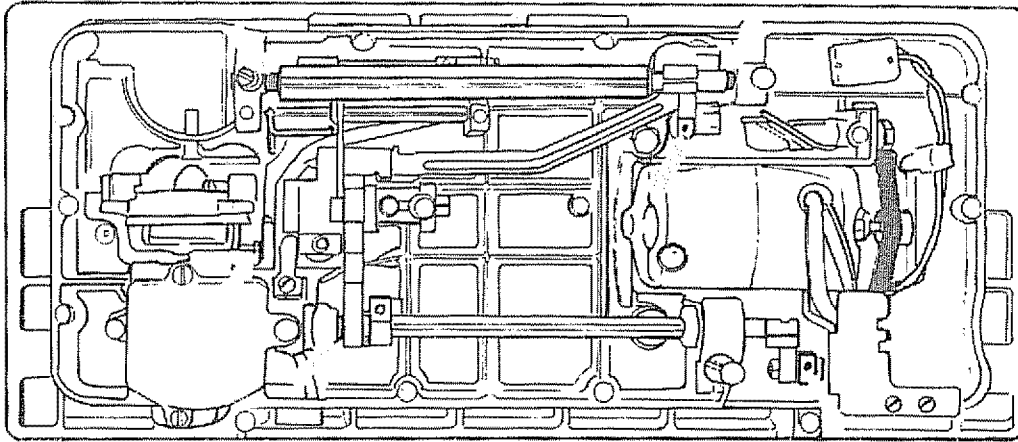

Swing hinged face cover plate open and oil points indicated in illustration.

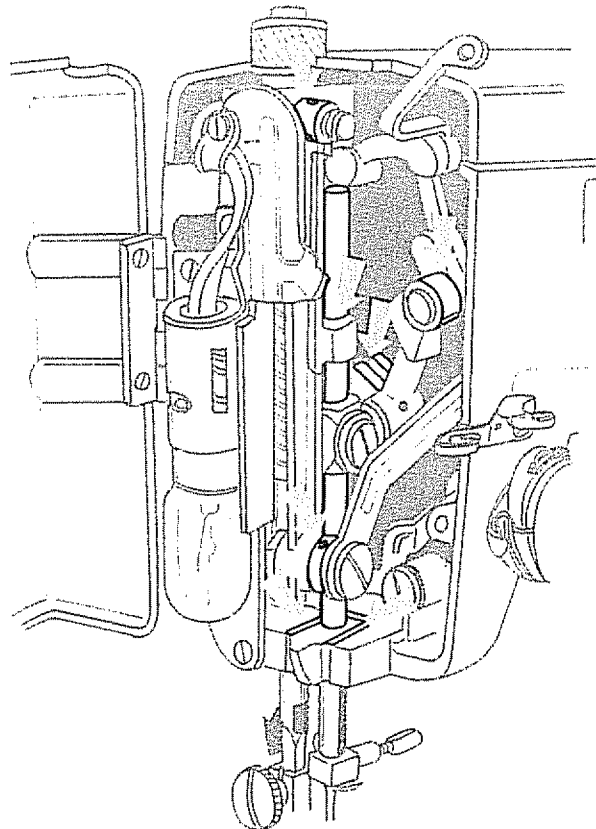

M E M O

Section IV
PAGE 4



1

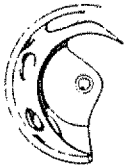

2



3

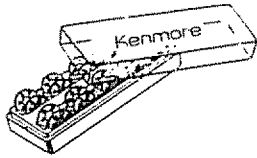

4



5



6



7



8



9

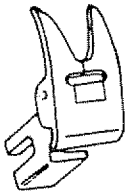

10

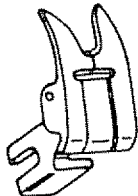

11



12

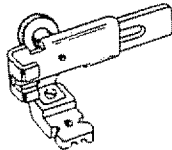

13

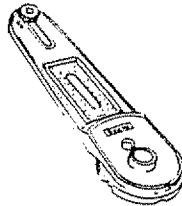

14



15

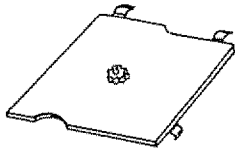

16

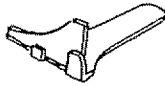

17



18

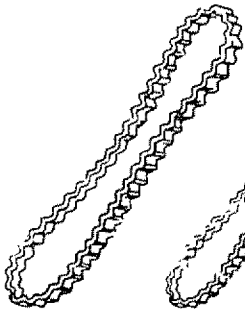

19

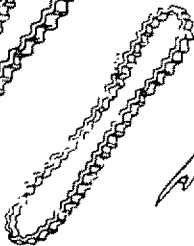

20

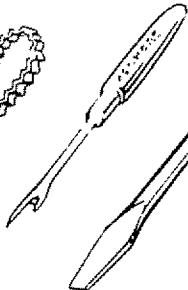

21

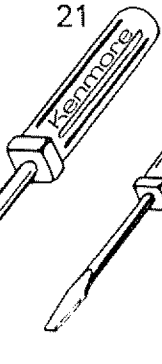

22

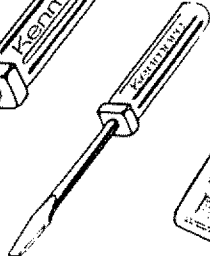

23



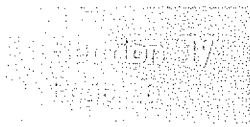

PARTS LIST

All parts listed herein may be ordered from any Sears, Roebuck and Co. or Simpsons-Sears Limited store or service center.

WHEN ORDERING REPAIR PARTS, ALWAYS GIVE THE FOLLOWING INFORMATION:

- 1. PART NUMBER
- 2. PART DESCRIPTION
- 3. MODEL NUMBER
- 4. NAME OF ITEM

If the parts you need are not stocked locally, your order will be electronically transmitted to a Sears Repair Parts Distribution Center for expedited handling.

Ref. #	Part #	Description
1	47	Shuttle
2	6510	Bobbin case
3	*6862	Bobbin box with 10 bobbins
4	1939	Bobbin winder rubber ring
5	8286	Thread spool pin
6	2273	Nylon disc
7	*6740	# 9 Single needles in orange case
	*6741	# 11 Single needles in yellow case
	*6742	# 14 Single needles in red case
	*6743	# 16 Single needles in green case
	*6744	# 18 Single needles in blue case
	*6746	Q NEEDLES in chocolate case
8	36353	Needle clamp with screw
9	40390	Standard zigzag foot
10	6870	Satin stitch foot
11	6873	Straight stitch foot
12	6757	Zipper foot
13	28889	Buttonhole guide plate
14	41695	Buttonhole and accessory case
15	36214	Buttonhole cover plate
16	6864	Needle threader
17	6797	Light bulb
18	28908	Large motor belt
19	30083	Small motor belt
20	6830	Buttonhole opener
21	41670	Large screw driver
22	41669	Small screw driver
23	*6889	Oil and lint brush

*These items are not furnished with the machine, but may be ordered per instructions above.

WARRANTY

FULL 25 - YEAR WARRANTY ON SEWING MACHINE HEAD

For 25 years from the first day of use in your home, Sears will, free of charge, repair defects in material or workmanship which appear in the sewing machine head

FULL TWO YEAR WARRANTY ON ELECTRICAL EQUIPMENT OF SEWING MACHINE

For two years from the first day of use in your home. Sears will, free of charge, repair defects in material or workmanship which appear in the electrical equipment of the sewing machine, including motor, wiring, switch and speed control.

FULL 90 - DAY WARRANTY ON ALL PARTS AND MECHANICAL ADJUSTMENTS

For 90 days from the first day of use in your home, Sears will, free of charge, replace any parts and provide mechanical service necessary for proper operation of the sewing machine, except for normal maintenance

To obtain warranty service described above, simply contact the nearest Sears store or Service Center throughout the United States or Canada.

This warranty gives you specific legal rights, and you may also have other rights which vary from state to state.

Simpsons - Sears Limited
Toronto, Ontario, Canada

Sears, Roebuck and Co.
BSC 41 - 3
Sears Tower
Chicago, IL 60684

SEWING MACHINE

Now that you have purchased your Sewing Machine, should a need ever exist for repair parts or service, simply contact any Sears Service Center and most Sears, Roebuck and Co. or Simpsons-Sears Limited Stores. Be sure to provide all pertinent facts when you call or visit.

The model number of your Sewing Machine will be shown on your nomenclature plate on the front side of bedplate of your Sewing Machine. See Section 1, Page 2 for location.

WHEN ORDERING REPAIR PARTS, ALWAYS GIVE THE FOLLOWING INFORMATION:

***MODEL NUMBER *NAME OF ITEM *PART DESCRIPTION**

If the parts you need are not stocked locally, your order will be electronically transmitted to a Sears Repair Parts Distribution Center for handling.

**SEARS, ROEBUCK AND CO., Chicago, IL 60684 U.S.A. and
SIMPSONS-SEARS LIMITED, Toronto, Ontario, Canada**